

Fin Mounting System Installation Procedure

The window and installation components should be inspected for any shipping damage. All local codes must be followed and supersede any of the following instructions. All finished surfaces of the window must be protected from damage to frame, paint, and glazing surfaces throughout the complete installation and wall finalization. This is to include stucco, drywall, brickwash or any other cleaning technique other than that recommended by Fyre-Tec. Failure to protect the window will VOID any applicable warranties. Protective coverings are recommended.

Opening Requirements

The opening should be built square and plumb and large enough to accept the window(s) provided. Windows are provided $\frac{3}{4}$ " less in both width and height from the rough or nominal opening size. This allows for a $\frac{3}{8}$ " gap around the entire perimeter of the window to be properly squared and shimmed in the opening. It is recommended that the sill of the window be shimmed no less than $\frac{1}{4}$ " above the construction sill to accommodate the weep feature of the window.

Opening Preparation

The window opening is to be prepared in conformance with local code and approved construction drawings. On openings other than masonry it is recommended that the perimeter be prepped with an air-barrier type window wrap and flashing system. Sill panning is recommended for optimal protection against water penetration. Panning and air barriers are not provided by Fyre-tec.

Fin Mounting to Window

The mounting fins are supplied loose and are to be mounted to the window with the self-tapping screws supplied. Window frame depth in relationship to the finished wall may be adjusted in four increments by selecting the mounting position on the perimeter of the frame as shown in the following layout.

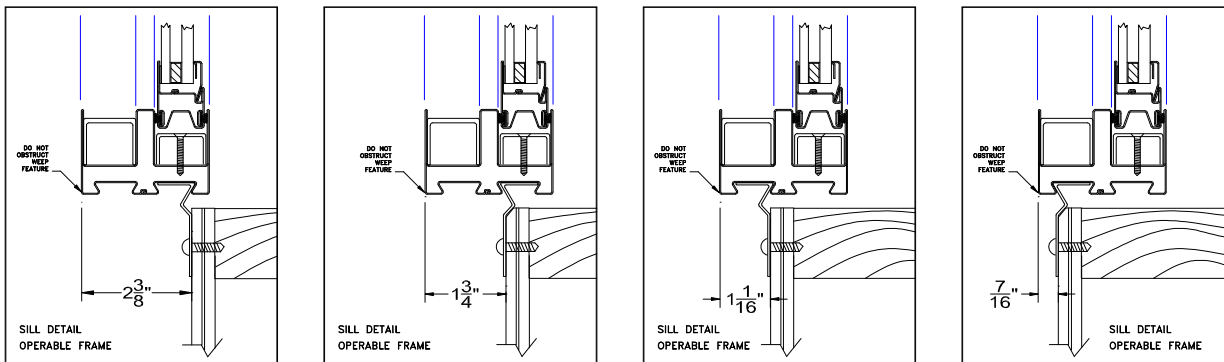

Attachment Procedure

1. *Pre-drill holes using a $\frac{3}{16}$ " bit in the fin to be mounted to the window (short leg). The screws are to be positioned 1" from each end of the individual fins and then placed 24" on center thereafter. The hole should be centered on the leg.
*Pre-drill holes using a bit large enough to accept fasteners being used in fin for mounting to wall (Long Leg). Hole locations should be no more than 3" from each end of the individual fins and then placed 16" on center thereafter. The holes should be placed in a known location as to allow fastener to penetrate a structural member of the wall.
2. Caulk bedding is to be applied around the perimeter of the frame in the frame recess that the fin is intended to be mounted. As shown (A). Any other holes or voids in the perimeter of the frame must be sealed as well to prevent water penetration into the wall cavity.
3. Screw the fin to the window as shown in (B) & (C)

(A)

(B)

(C)



Note: The sill of **operable windows** have additional factory applied butyl tape to further assist in preventing water leaking into wall cavity.

Window Installation in Opening

Installation will require a minimum of two people.

One individual should remain on the exterior to hold the window in place and the other on the interior to center the window in the opening using a flat pry-bar or shim. All sides on the interior should have approximately 3/8" gap from wall opening to window edge. Shim using an approved material. Check window for level in the opening and complete shim application. Once the window is shimmed properly, attach the fin on the exterior to a structural member per an approved method as laid out by an architect or authority having jurisdiction. Special attention should be made with the weep feature of the window in the exterior sill. A minimum 1/4" gap should be maintained between the sill of the window and the construction sill of the wall to allow for proper weeping and drainage from the window.



INTERIOR



EXTERIOR



When attaching the Fin to the wall section keep the corners loose to apply the Fin corner pieces. Caulk corner of wall where Fin will be placed as seen in picture to (left). Pull fin away from wall slightly and slide fin underneath as shown in picture (lower left). Once all Fin corners are installed caulk all exposed seams using an approved sealant shown (lower right). The window is now ready to be flashed.



Flashing the Installation

Flashing the exterior gives added protection against water penetration. The recommended procedure for flashing the opening is to use a flexible adhesive backed window wrap. Each application of the window wrap should be cut extra long as to allow over lapping in each of the corners, at least the width of the wrap itself. The wrap should contact the window frame and be applied per manufacture specification.

If stucco is the desired finished wall exterior a J-channel trim must be used to keep the stucco from contacting the perimeter of the window frame. Protection against stucco from getting on the window and glazing surfaces is important.

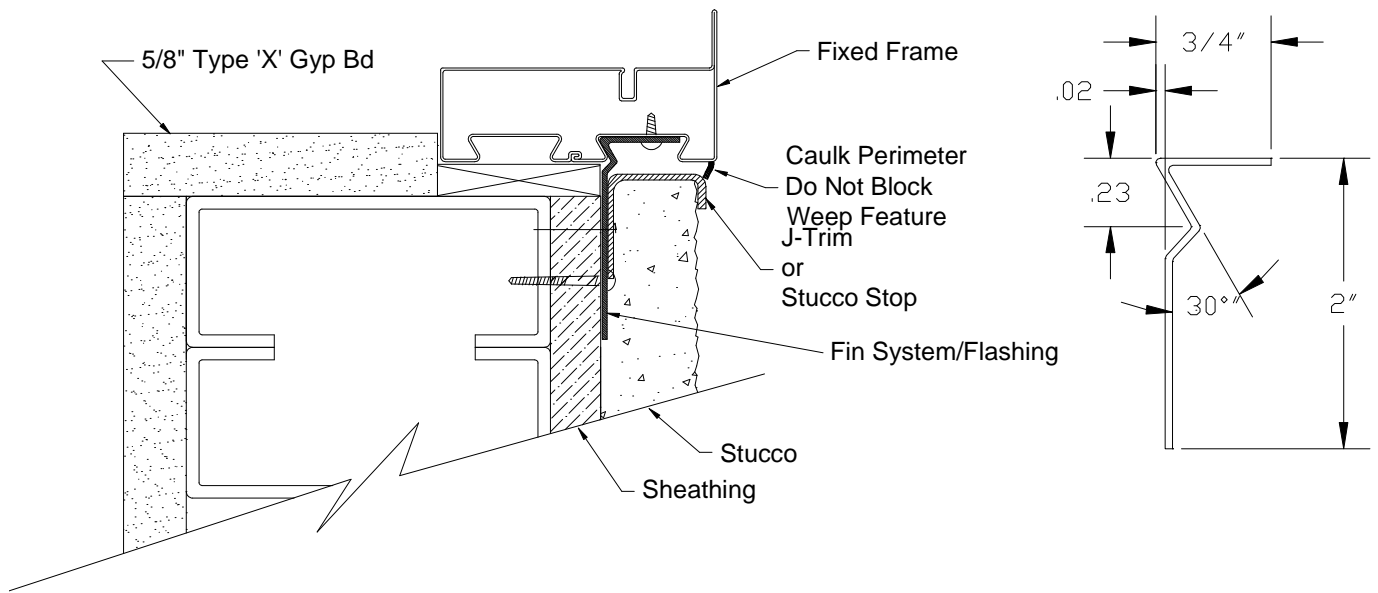

Finalizing the Installation & Weep Feature

Once the wall construction is complete and stucco, siding, masonry or other application is complete, a perimeter beading of approved sealant is needed. Use caution when sealing around the weep feature.

The weep feature is a very important part in the longevity of the window's life span. On exterior applications special attention should be made to the exterior sill and the windows weep feature. The weep located 2" in from both corners of the sill and should be inspected or verified that the weep is open to a gap of 1/8" by approximately 7/8" long. Verification ensures that the weep has not been pinched down or crimped shut during shipping, handling, and installation. Failure to inspect the weep feature prior to finalizing the project can lead to water leakage as well as premature rusting with the window. If the slot needs additional adjustment carefully use a flat screwdriver or small pry-bar to make the gap more. Do not use excessive force, which can cause the frame to tear or crack the protective paint.



Tools Recommended:

- | | | |
|-----------------|---------|---|
| -Safety glasses | -Pencil | -Power tool with drilling and screwing capabilities |
| -Measuring tape | -Hammer | -Saw or power saw with metal cutting capabilities |
| -Caulking Gun | -Level | -Pry-bar for shimming and squaring |

Supplies Needed:

Notice All supplies must be approved and meet local code requirements. Contact your local inspector for a list of their approved products.

- | | | |
|----------|------------|--------|
| -Sealant | -Fasteners | -Shims |
|----------|------------|--------|

Parts Shipped

Contained within each individual crate supplied are:

- 1-Window
- *1-Trim kit containing:
 - Instructions
 - 1-Head Fin
 - 1-Sill Fin
 - 2-Jamb Fins
 - 4-Fin Corners
 - **Touchup paint



**Screws for applying fin

(Not shown)

Mullions if applicable

Notes:

The window and parts should be inspected for shipping damage prior to installation

*If trim kit exceeds the length of the window it will be provided in separate box.

**Note: Depending upon the quantity of windows, touchup paint and screws may be provided in larger bags with enough quantity to cover the whole order. These bags will be attached to only one or several trim kits depending on order quantity. Location of these items will be identified on the shipped crate being marked as "SCREWS"